

TEAR
system

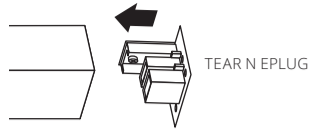

TEAR N EPLUG

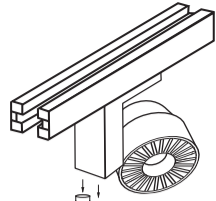
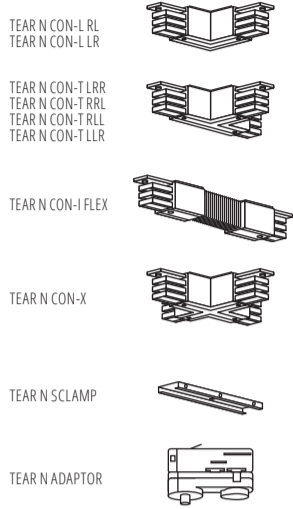
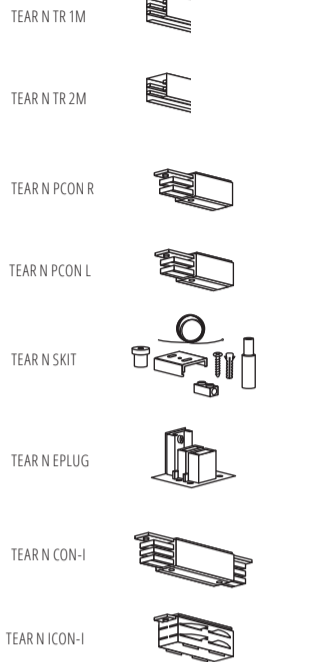

TEAR N 1M max 10kg
TEAR N 2M max 15kg

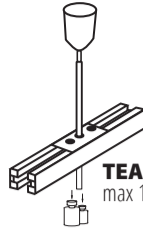

TEAR N SKIT
max 10kg

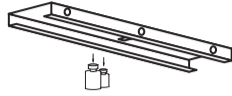

TEAR N SCLAMP
max 10kg

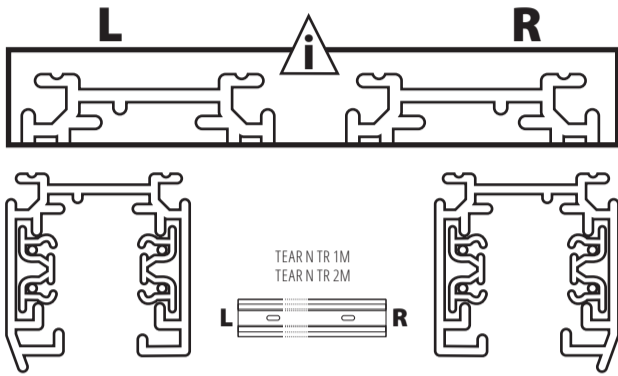

TEAR
system

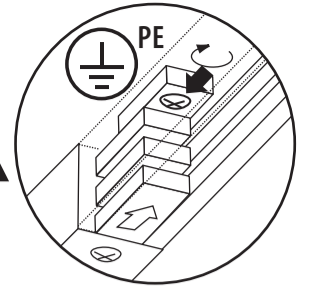

220-240V~
50Hz

TEAR N TR 1M
TEAR N TR 2M

TEAR N PCON R

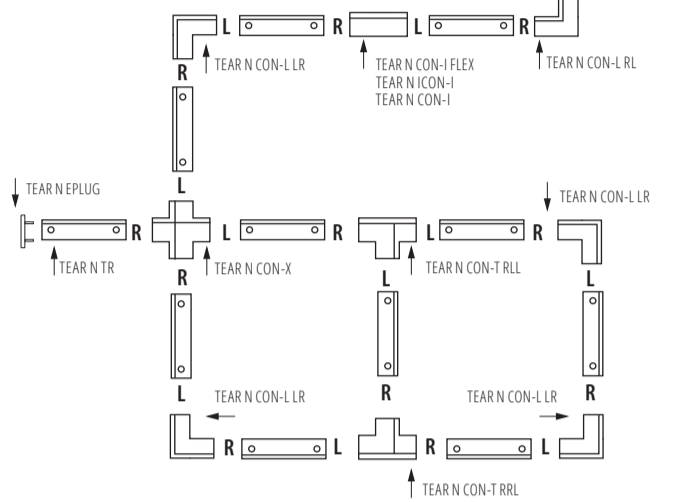

A/1

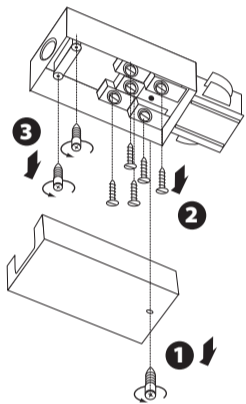

A/2

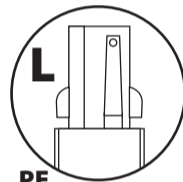
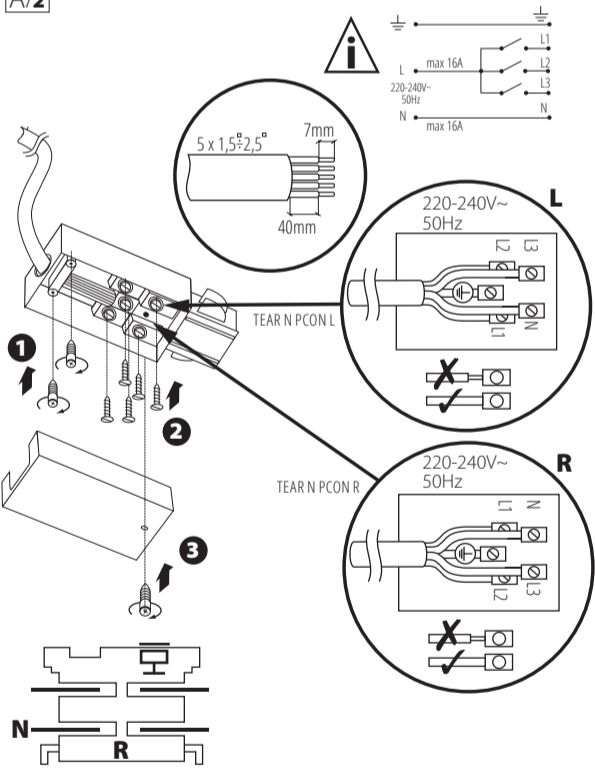

PE

L2 L1

L3 N



PE

L1 L2

N L3

N — color BLUE

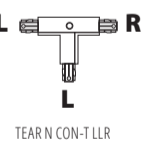
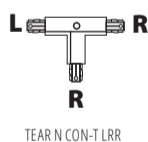
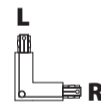
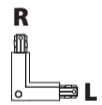
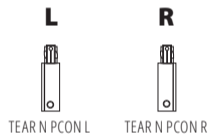

TEAR N SKIT

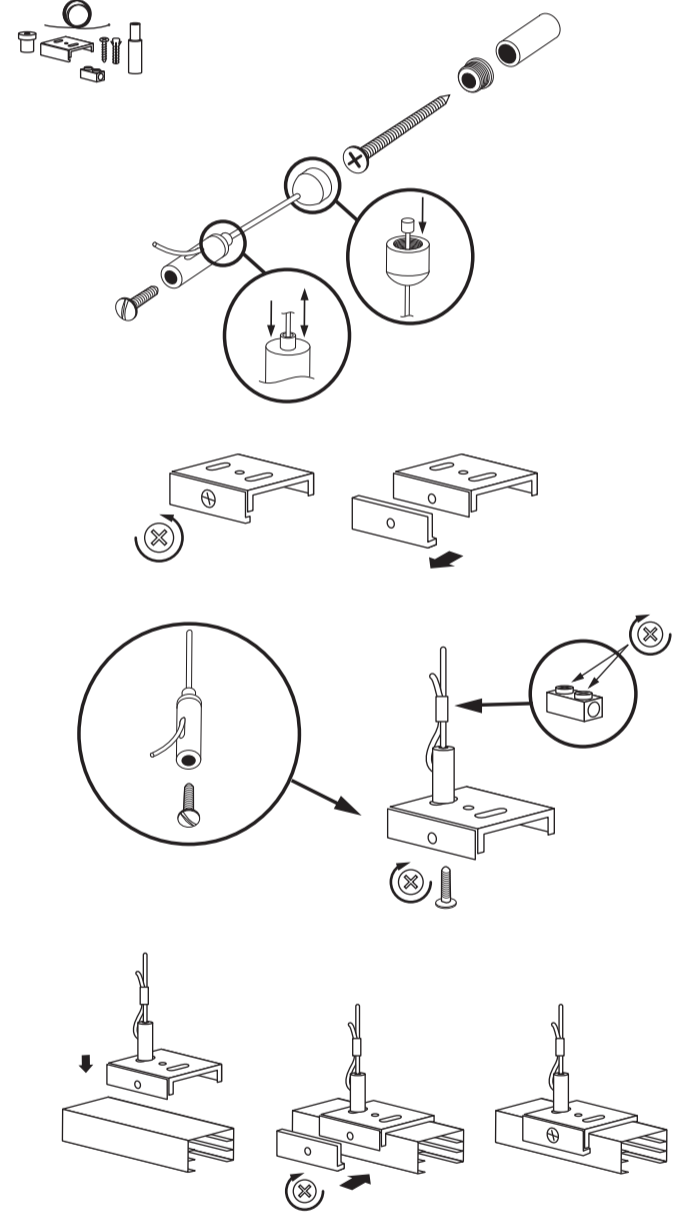

TEAR N SCLAMP

