

STRETON LED

Oprawa parkingowa LED



[V] 220-240 AC	[Hz] 50	360° Φ _{use}	≥20000	(h) 50000	ellipse ≤ 6x Nachdam	Ra 70
SMD			IP 65		°C -20÷45	
IK 08		[m] 0,4	[mm²] 1	1m	Hg	CE
EAC	UK CA					



STRETON LED 20W NW



Model	Power [W]	Beam Angle [°]	Beam Diameter [m]	Beam Spread [m]	Beam Spread [mm²]	Color	Beam Spread [m]
STRETON LED 20W NW	36228	20	2800	4000	X140/Y90	szary	D
STRETON LED 40W NW	36229	40	5600	4000	X140/Y90	szary	D
STRETON LED 60W NW	36230	60	8400	4000	X140/Y90	szary	D
STRETON LED 100W NW	36231	100	14000	4000	X140/Y90	szary	D
STRETON LED 150W NW	36232	150	19500	4000	X140/Y90	szary	E
STRETON LED 200W NW	36233	200	26000	4000	X140/Y90	szary	E

Kanlux STRETON LED to oprawy zewnętrzne przeznaczone do oświetlania parkingów czy większych powierzchni, które muszą być dobrze oświetlone również po zmroku. Ich trwałość (50.000 godzin), szczelność (IP65) i wysokie moce (do 200W) sprawiają, że Kanlux STRETON LED idealnie uzupełnią inwestycję w przestrzeni miejskiej, na parkingach, w obiektach sportowych czy placach lub skwerach.

- 5 lat Gwarancji na warunkach oświadczenia gwarancyjnego, dostępnego na stronie internetowej
- Materiał obudowy: stop aluminium
- Materiał szyby ochronnej: PC

STRETON LED

Oprawa parkingowa LED



STRETON LED 20W NW



STRETON LED 40W NW



STRETON LED 60W NW



STRETON LED 100W NW



STRETON LED 150W NW



STRETON LED 200W NW

STRETON LED

Oprawa parkingowa LED

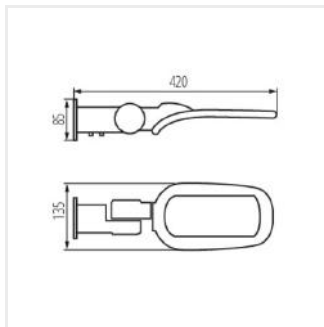

STRETON LED 20W NW

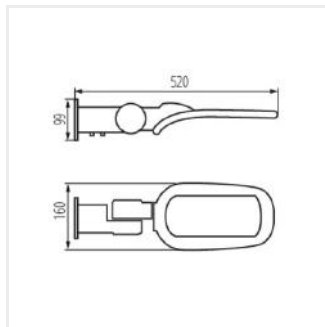

STRETON LED 40W NW

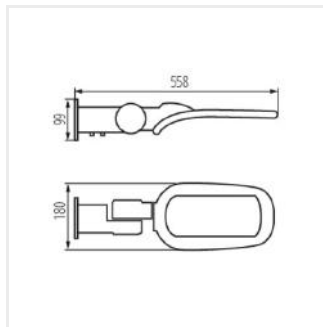

STRETON LED 60W NW

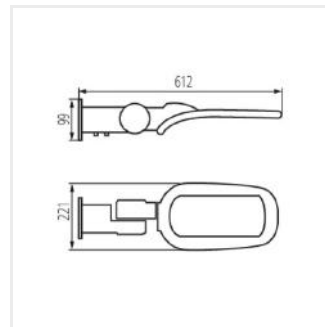

STRETON LED 100W NW

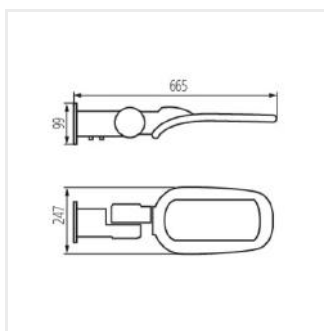

STRETON LED 150W NW

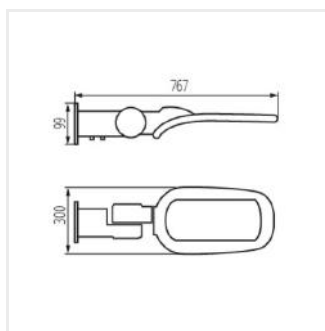

STRETON LED 200W NW

OPTION 1

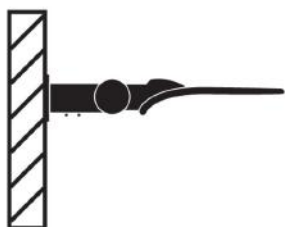

OPTION 2

