

## STRETON LED

### Oprawa parkingowa LED

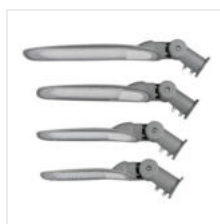

[V] 220-240 AC	[Hz] 50	360° Φ <sub>use</sub>	≥20000	(h) 50000	ellipse ≤ 6x Nachdam	Ra 70
SMD			IP 65		°C -20÷45	
IK 08		[m] 0,4	[mm] 1	1m	Hg	CE
EAC	UK CA					



### STRETON LED 20W NW



Model	Power [W]	Beam Angle [°]	Beam Spread [m]	Temperature [K]	Beam Spread [m]	Color	Beam Spread [m]
STRETON LED 20W NW	<b>36228</b>	20	2800	4000	X140/Y90	szary	D
STRETON LED 40W NW	<b>36229</b>	40	5600	4000	X140/Y90	szary	D
STRETON LED 60W NW	<b>36230</b>	60	8400	4000	X140/Y90	szary	D
STRETON LED 100W NW	<b>36231</b>	100	14000	4000	X140/Y90	szary	D
STRETON LED 150W NW	<b>36232</b>	150	19500	4000	X140/Y90	szary	E
STRETON LED 200W NW	<b>36233</b>	200	26000	4000	X140/Y90	szary	E

Kanlux STRETON LED to oprawy zewnętrzne przeznaczone do oświetlania parkingów czy większych powierzchni, które muszą być dobrze oświetlone również po zmroku. Ich trwałość (50.000 godzin), szczelność (IP65) i wysokie moce (do 200W) sprawiają, że Kanlux STRETON LED idealnie uzupełnią inwestycję w przestrzeni miejskiej, na parkingach, w obiektach sportowych czy placach lub skwerach.

- 5 lat Gwarancji na warunkach oświadczenia gwarancyjnego, dostępnego na stronie internetowej
- Materiał obudowy: stop aluminium
- Materiał szyby ochronnej: PC

## STRETON LED

---

Oprawa parkingowa LED



STRETON LED 20W NW



STRETON LED 40W NW



STRETON LED 60W NW



STRETON LED 100W NW



STRETON LED 150W NW



STRETON LED 200W NW

## STRETON LED

### Oprawa parkingowa LED

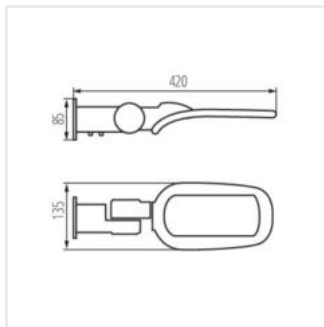

STRETON LED 20W NW

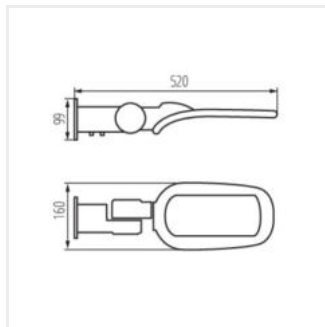

STRETON LED 40W NW

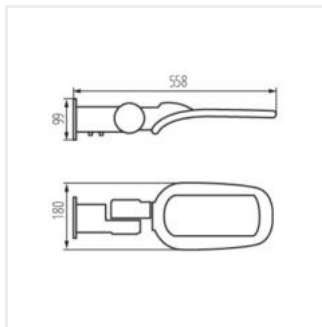

STRETON LED 60W NW

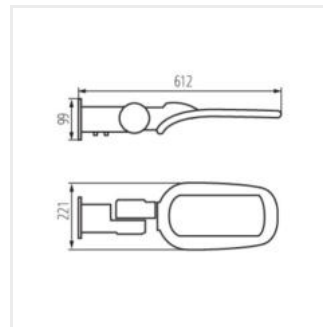

STRETON LED 100W NW

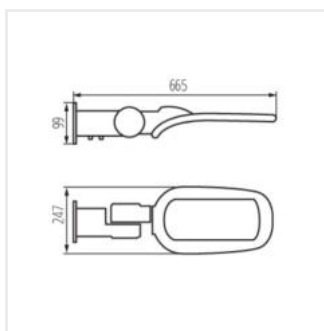

STRETON LED 150W NW

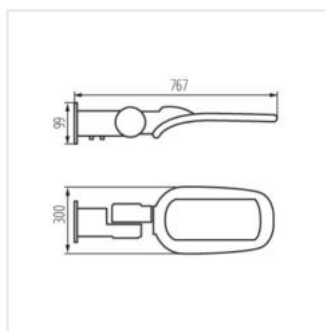

STRETON LED 200W NW

### OPTION 1

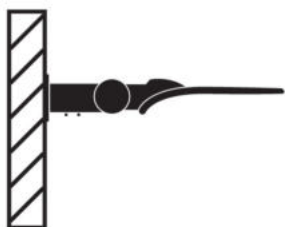

### OPTION 2

